

IFBR1a/E01

TECHNICAL DATA

UHF Multi-Frequency Belt-Pack IFB Receiver

- Preset (default) frequency is manually set with hex switches
- Scan mode stores up to five additional frequencies in memory
- Multi-color LED and rotary control for programming and operation
- High sensitivity for extended operating range indoors or outdoors
- Rugged machined aluminum housing
- Attached battery door
- 8 hours battery life (alkaline)
- 20 hours battery life (lithium)
- Protective leather pouch is included



Wireless IFB (interruptible fold back) systems are used for talent cueing and crew communications in broadcast and motion picture production. In other cases, the IFB system is used by directors and other management to monitor program audio during a production. The IFB R1a receiver provides simplicity and flexibility in a package that is intuitive for untrained users to operate.

The default frequency of the receiver is set by two rotary switches on the side panel. Up to five additional frequencies can also be programmed into the receiver memory using the scan mode. If more than one frequency is stored in the receiver, the operator can scroll through all stored frequencies by simply pressing the volume knob.

Basic operation is simply a matter of rotating the knob to turn power on and adjusting the volume level. Additional frequencies are added by holding the knob in until the LED begins blinking and the receiver begins to scan. The receiver will search for signals that contain a pilot tone and automatically stop scanning and wait for the operator to either store that frequency or continue scanning.

A special button push sequence is required to set the receiver into the scanning mode to prevent accidental changes to the receiver memory. Simplified instructions are laser engraved into the housing of the receiver.

The scanning process is performed at two different sensitivity levels. The first scan is performed at a reduced sensitivity to avoid falsely locking onto IM (intermodulation) signals rather than true carriers. This reduced sensitivity scan is necessary when the unit is programmed in close proximity to the transmitter. If no signals are found in the first scan, a single button push will set the receiver to full sensitivity and begin a second scan. Full sensitivity scanning is necessary to program the receiver at a distance away from the transmitter.

The design uses +/-20 kHz FM deviation for efficient use of the bandwidth, with compandor noise reduction circuitry for an excellent signal to noise ratio. A supersonic Pilot Tone signal controls the audio output squelch to keep the receiver silent when no transmitter signal is received.

The receiver operates on a single 9 volt alkaline or lithium battery. Alkaline battery life is up to 8 hours. Lithium battery life is well over 20 hours. The LED indicator changes color from green, to yellow, to red as the battery voltage declines to provide plenty of warning before operation ceases.

An internal relay in the receiver will automatically detect a monaural plug connected to the output jack and switch accordingly. Full output power is available with either type of connector, without the power losses that result from a resistive circuit design. The antenna input is provided by the shield of the cable and headset or earphone connected to the output jack.

The receiver will drive a wide variety of earbuds, headphones and induction neck loops at substantial levels, with loads from 16 Ohms to 600 Ohms.

The receiver is housed in a rugged machined aluminum package. A spring-loaded belt clip is available as an accessory which provides a secure mounting on a wide variety of belts, pockets and fabrics.

R1a Block Diagram

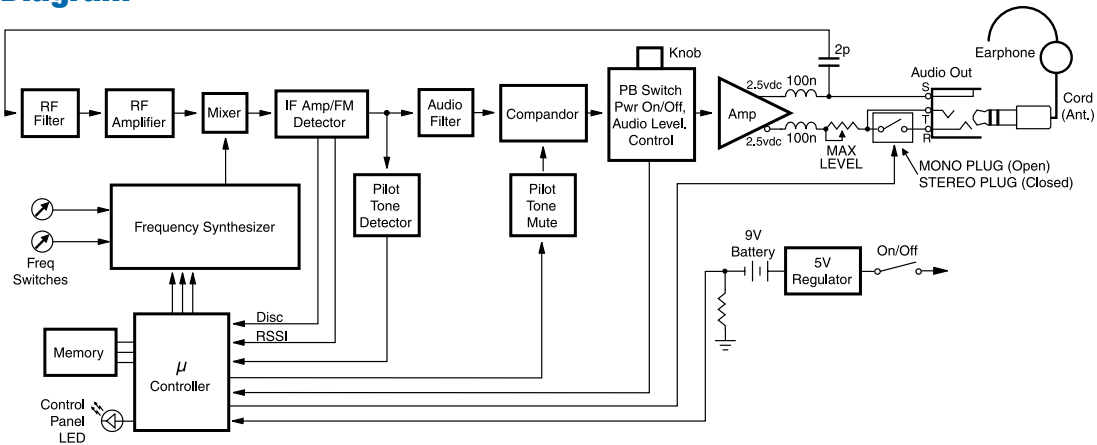

The R1a comes with a protective leather pouch with an integrated belt clip.

The incoming RF signal is filtered and amplified, then mixed down to the IF frequency with a microprocessor controlled synthesizer. A pilot tone squelch system is used to keep the receiver silent when no carrier is present. The pilot tone signal is on a different frequency than Lectrosonics UHF wireless microphone systems to prevent interference when the systems are used in the same location. The audio signal processing includes compressor noise reduction for low noise and excellent intelligibility.

An attached rotating door makes battery installation easy.



The receiver is housed in a compact machined aluminum enclosure. The unit features an integral rotating battery door that remains attached to the housing when opened. All nomenclature is laser engraved into the housing to withstand physical abrasion and heavy use. A condensed instruction set is also laser etched into the side panel of the receiver.

Specifications

Operating Frequencies:

| | | | |
|-----------|-------------------|-----------|------------------------------------|
| Block 470 | 470.100 - 495.600 | Block 606 | 606.000 - 631.5 (100 kHz Steps) |
| Block 19 | 486.400 - 511.900 | | |
| Block 20 | 512.000 - 537.500 | | |
| Block 21 | 537.600 - 563.100 | | |
| Block 22 | 563.200 - 588.700 | | |
| Block 23 | 588.800 - 614.300 | | |
| Block 24 | 614.400 - 639.900 | | |
| Block 25 | 640.000 - 665.500 | | |
| Block 26 | 665.600 - 691.100 | | |
| Block 27 | 691.200 - 716.700 | | |
| Block 28 | 716.800 - 742.300 | | |
| Block 29 | 742.400 - 767.900 | | |
| Block 30 | 768.000 - 793.500 | | |
| Block 31 | 793.600 - 819.100 | | |
| Block 32 | 819.200 - 844.700 | | |
| Block 33 | 844.800 - 861.900 | | |

| | |
|----------------------------|------------------------|
| Frequency control: | Crystal Controlled PLL |
| Sensitivity: | 1 uv (20 dB SINAD) |
| Signal/Noise ratio: | 95 dB A-weighted |
| Squelch quieting: | 90 dB |
| AM rejection: | 50 dB, 10 uV to 100 mV |

| | |
|-------------------------------|---|
| Modulation acceptance: | ±20 kHz (±25 kHz deviation max.) |
| Spurious rejection: | Greater than 70 dB |
| Third order intercept: | 0 dBm |
| Frequency response: | 100 Hz to 10 kHz, (±1db) |
| Pilot tone: | 29.997 kHz, 2 kHz deviation (fixed crystal controlled) |
| Audio output: | 1V RMS into 50 Ohms minimum |
| Antenna: | Headphone cable |
| Programmable memory: | Switches set default frequency; up to five additional frequencies can be stored in memory |
| Front panel controls: | Single knob controls Audio Output Level, Power On, Programming and Scan Frequency Selection |
| Indicators: | Multi-color LED indicator for power on and battery status. Blinks to indicate channel number and during scanning. |
| Power requirement: | 9V alkaline battery lasts about 8 hours 9V lithium battery lasts about 20 hours |
| Power consumption: | 60 mA |
| Weight: | 7.3 oz with battery |
| Size: | 3.6 x 2.4 x 0.8 inches (housing only) |



581 Laser Road NE • Rio Rancho, NM 87124 USA • www.lectrosonics.com
(505) 892-4501 • (800) 821-1121 • fax (505) 892-6243 • sales@lectrosonics.com

CE 1313

19 July, 2010